

# Illustration Auswurf-träger fangkorb

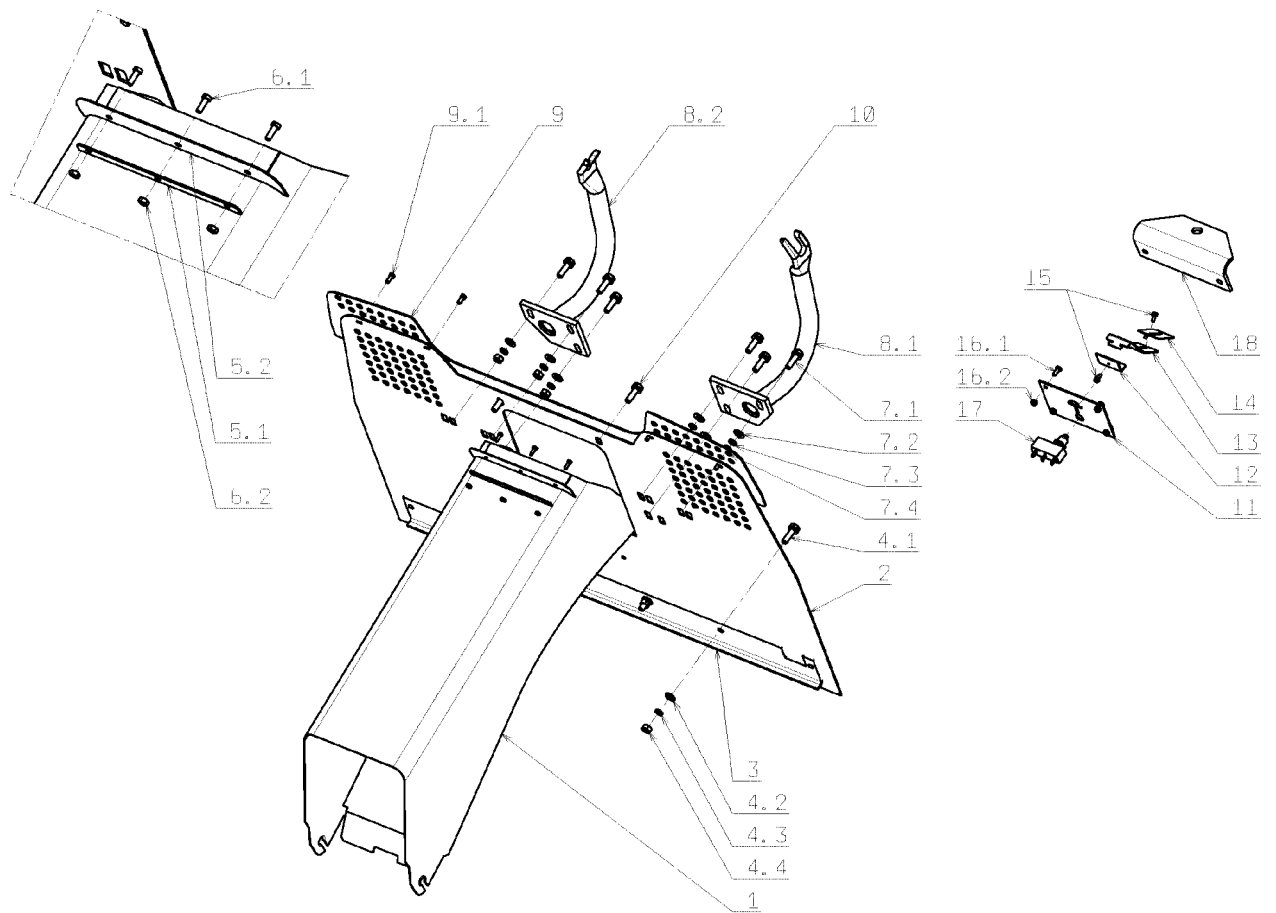

## Illustration    Auswurf-träger fangkorb

---

Bild Nr.	St.- Zahl	Teile Nr.	Beschreibung
1	1	SGS53297447226:	Tunnel
2	1	SGS53297442219:	Platte
3	1	SGS53211340323:	Verstaerkung
4.1	4	SGN309578011	Schraube
4.2	4	SGN311210503	Scheibe
4.3	4	SGN311214502	Scheibe
4.4	4	SGN311150503	Mutter
5.1	1	SGS53211530857:	Gurt
5.2	1	SGN273192015	Bende
6.1	3	SGN309231502	Schraube
6.2	3	SGN311120505	Mutter
7.1	6	SGN309578012	Schraube
7.2	6	SGN311210503	Scheibe
7.3	6	SGN311214502	Scheibe
7.4	6	SGN311150503	Mutter
8.1	1	SGS53297443216:	Halter
8.2	1	SGS53297443217:	Halter
9	1	SGS53207430229:	Verlaengerung
9.1	4	SGN309315010	Schraube
10	2	SGN309503005	Schraube
11	1	SGS53211430788:	Plattform
12	1	SGS53211340468:	Halter
13	1	SGS53201441473:	Plattform
14	1	SGS53201441474:	Plattform
15	2	SGN309315012	Schraube
16.1	4	SGN309203539	Schraube
16.2	4	SGN311129515	Mutter
17	-	-	Nicht verfügbar für diesen produkt
18	1	SGN532150296	Aufhängung

# Illustration    Eletrischeile

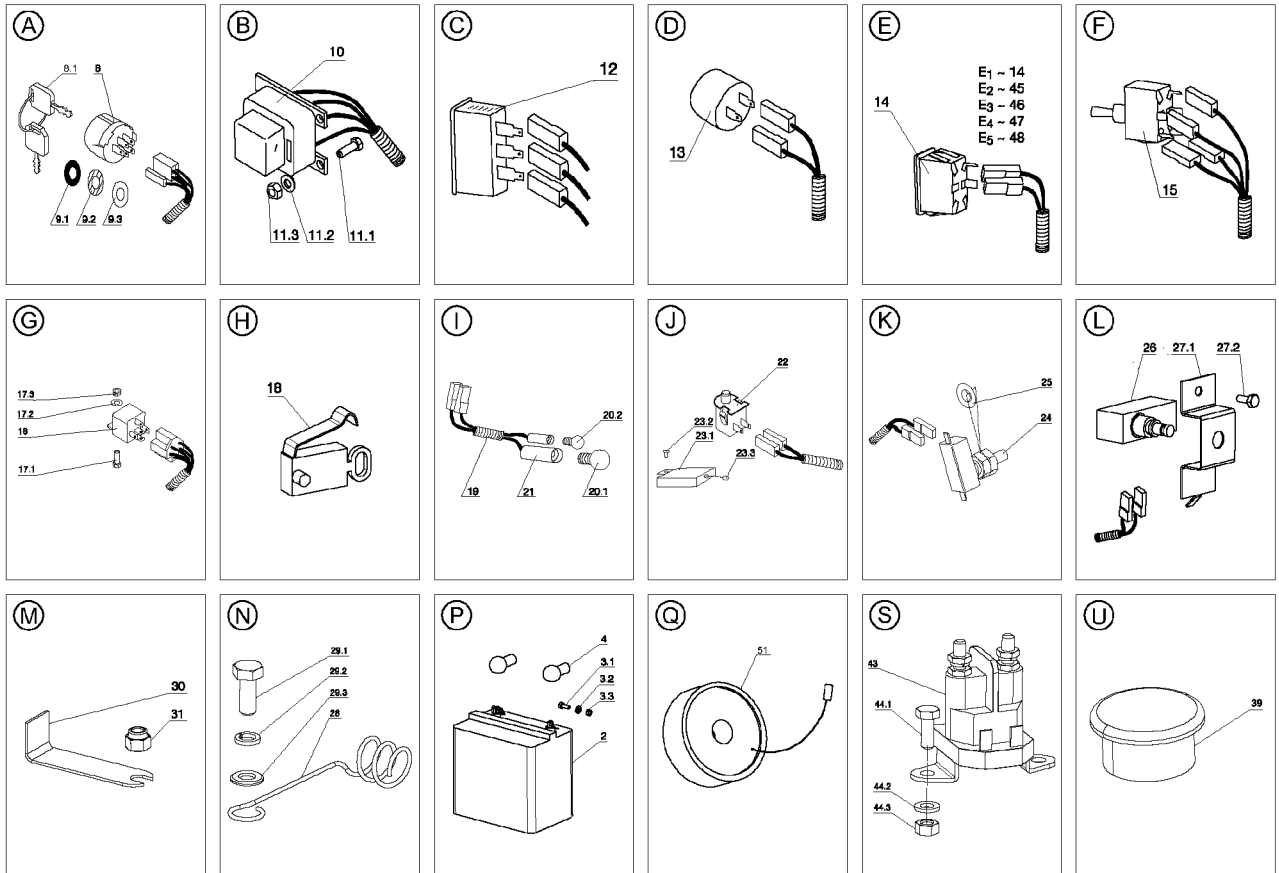

## Illustration    Eletrischeteile

Bild Nr.	St.- Zahl	Teile Nr.	Beschreibung
2	1	SGN346211006	Batterie
3.1	2	SGN309503548	Schraube
3.2	2	SGN311210502	Scheibe
3.3	2	SGN311129513	Mutter
4	2	SGN273125006	Deckel
8	1	SGN443861006	Box
8.1	1	SGN443900137	Schlüssel
9.1	-	-	Nicht verfügbar für diesen produkt
9.2	-	-	Nicht verfügbar für diesen produkt
9.3	-	-	Nicht verfügbar für diesen produkt
10	-	-	Nicht verfügbar für diesen produkt
11.1	2	SGN309203548	Schraube
11.2	4	SGN311210501	Scheibe
11.3	2	SGN311129515	Mutter
12	1	SGN443433002	Behaelter
13	1	SGN443312021	Warnlicht
14	1	SGN345329013	Schalter
15	1	SGN345329022	Schalter
17.1	3	SGN309203548	Schraube
17.2	3	SGN311210501	Scheibe
17.3	3	SGN311129515	Mutter
18	1	SGN345329020	Schalter
19	1	SGN341271036	Glühbirnen
20.1	2	SGN347224006	Glühlampe
20.2	-	-	Nicht verfügbar für diesen produkt
21	2	SGN443953001	Halter
22	1	SGN000532079	Sitzschalter
23.1	1	SGS53208542715:	Deckel
23.2	1	SGN311691001	Niete
23.3	1	SGN273121035	Buchse
24	1	SGN345359004	Micro-schalter
25	-	-	Nicht verfügbar für diesen produkt
26	1	SGN345359004	Micro-schalter
27.1	1	SGS53208541581:	Deckel
27.2	1	SGN309315011	Schraube
28	1	SGN532150125	Halter
29.1	1	SGN309503518	Schraube
29.2	1	SGN311214502	Scheibe
29.3	1	SGN311210503	Scheibe
30	1	SGS53211340258:	Halter
31	2	SGN311129515	Mutter
39	1	SGN321841068	Blechtafel
43	1	SGN000532033	Solenoid

# Illustration    Eletrischeile

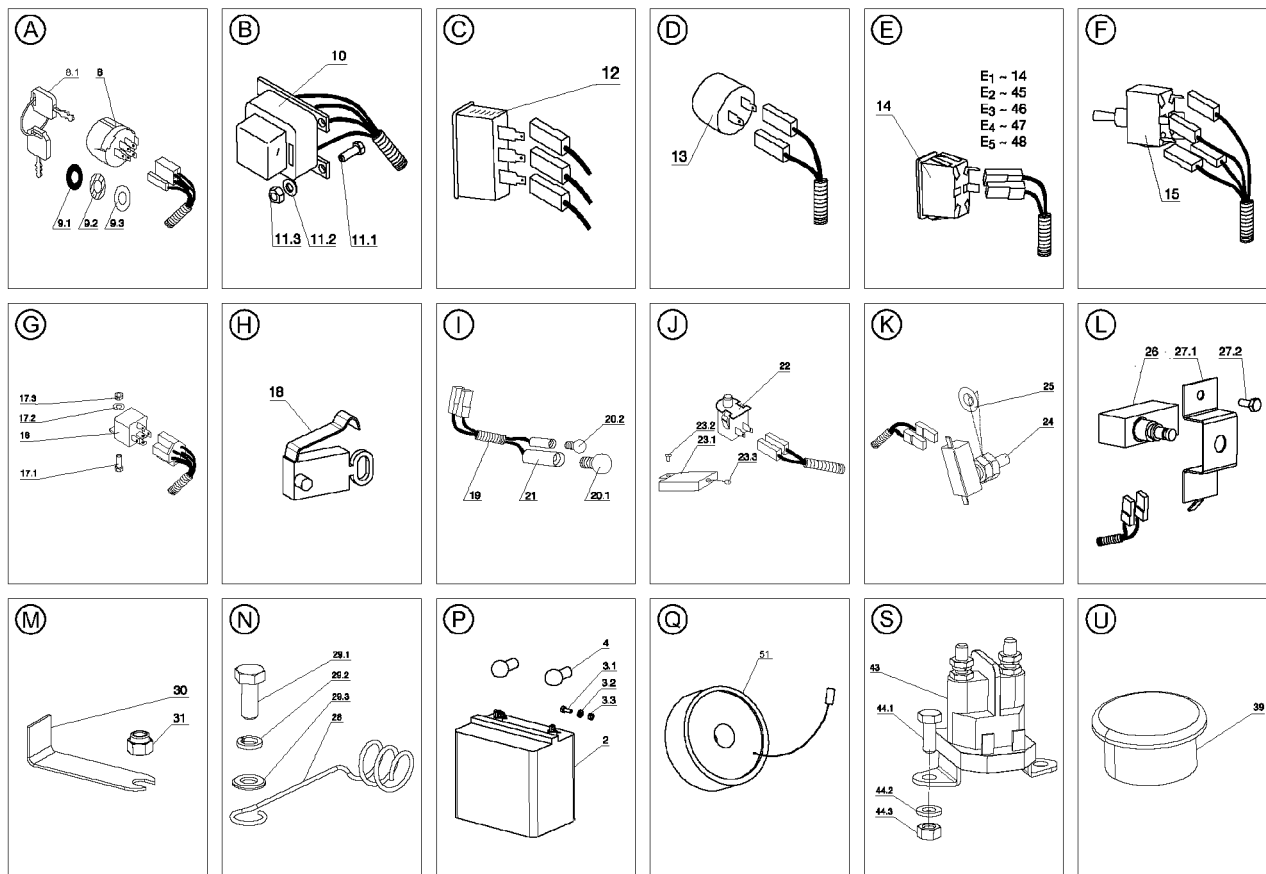

## Illustration    Eletrischeteile

---

Bild Nr.	St.- Zahl	Teile Nr.	Beschreibung
44.1	2	SGN309503508	Schraube
44.2	2	SGN311210502	Scheibe
44.3	2	SGN311129513	Mutter
45	-	-	Nicht verfügbar für diesen produkt
46	-	-	Nicht verfügbar für diesen produkt
47	-	-	Nicht verfügbar für diesen produkt
48	-	-	Nicht verfügbar für diesen produkt
51	-	-	Nicht verfügbar für diesen produkt

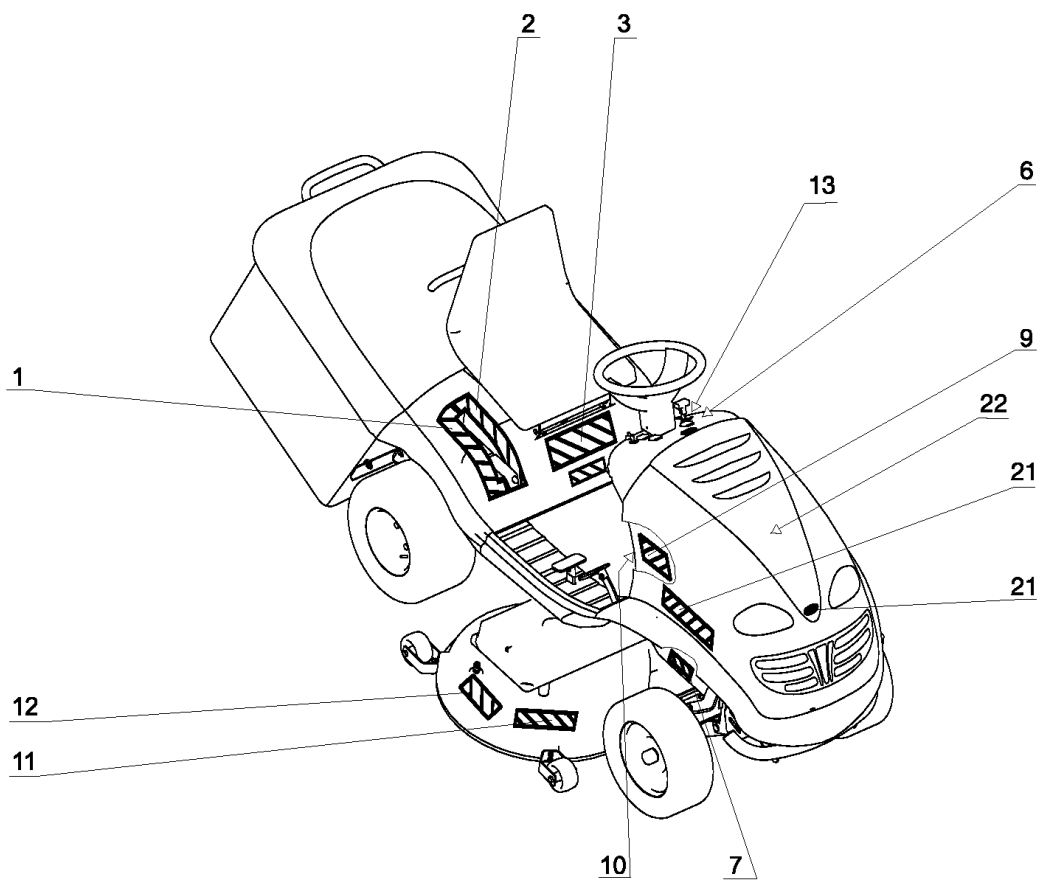
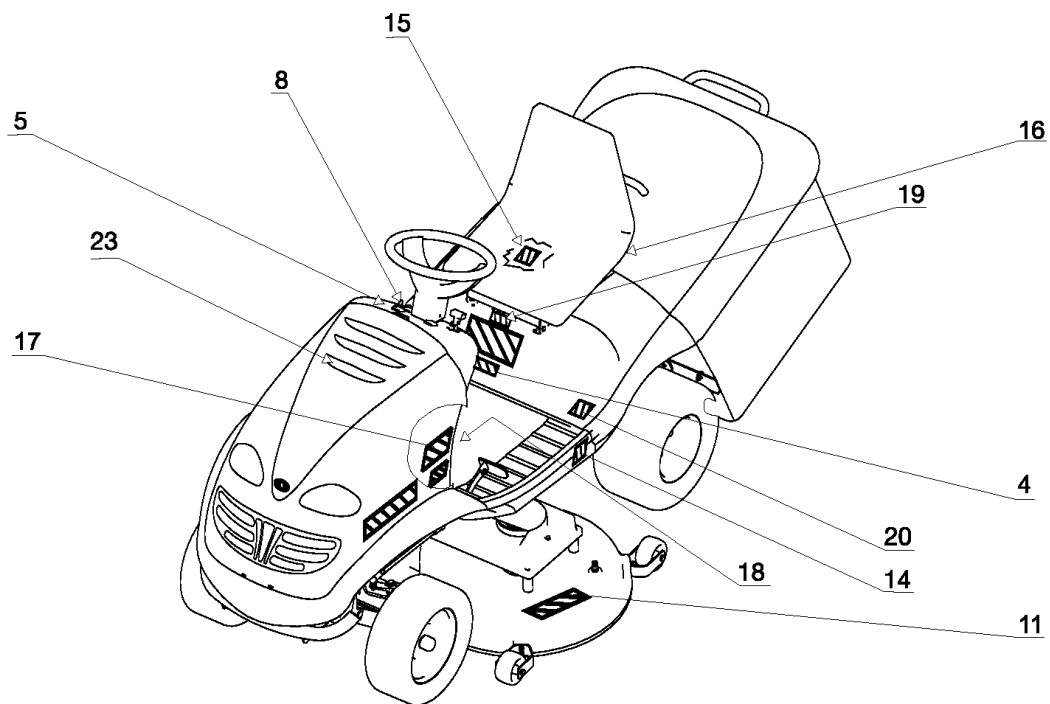

## Illustration    Etiketten

---

Bild Nr.	St.- Zahl	Teile Nr.	Beschreibung
1	1	SGN283292614	Etikette
2	1	SGN283292615	Etikette
3	1	SGN283292159	Etikette
4		-	Nicht verfügbar für diesen produkt
5		-	Nicht verfügbar für diesen produkt
6	1	SGN283292623	Etikette
7	2	SGN283292223	Etikette
8		-	Nicht verfügbar für diesen produkt
9	1	SGN283292327	Etikette
10	1	SGN283292228	Etikette
11	2	SGN283292121	Etikette
12		-	Nicht verfügbar für diesen produkt
13	1	SGN283292622	Etikette
14	1	SGN283292192	Etikette
15		-	Nicht verfügbar für diesen produkt
16	1	SGN283292126	Etikette
17	1	SGN283292302	Etikette
18	1	SGN283292230	Etikette
19		-	Nicht verfügbar für diesen produkt
20		-	Nicht verfügbar für diesen produkt
21	1	SGS53298601275:	Etikette
22	1	SGN735411026	Etikette
23	1	SGN735411025	Etikette



# Illustration    Getriebe

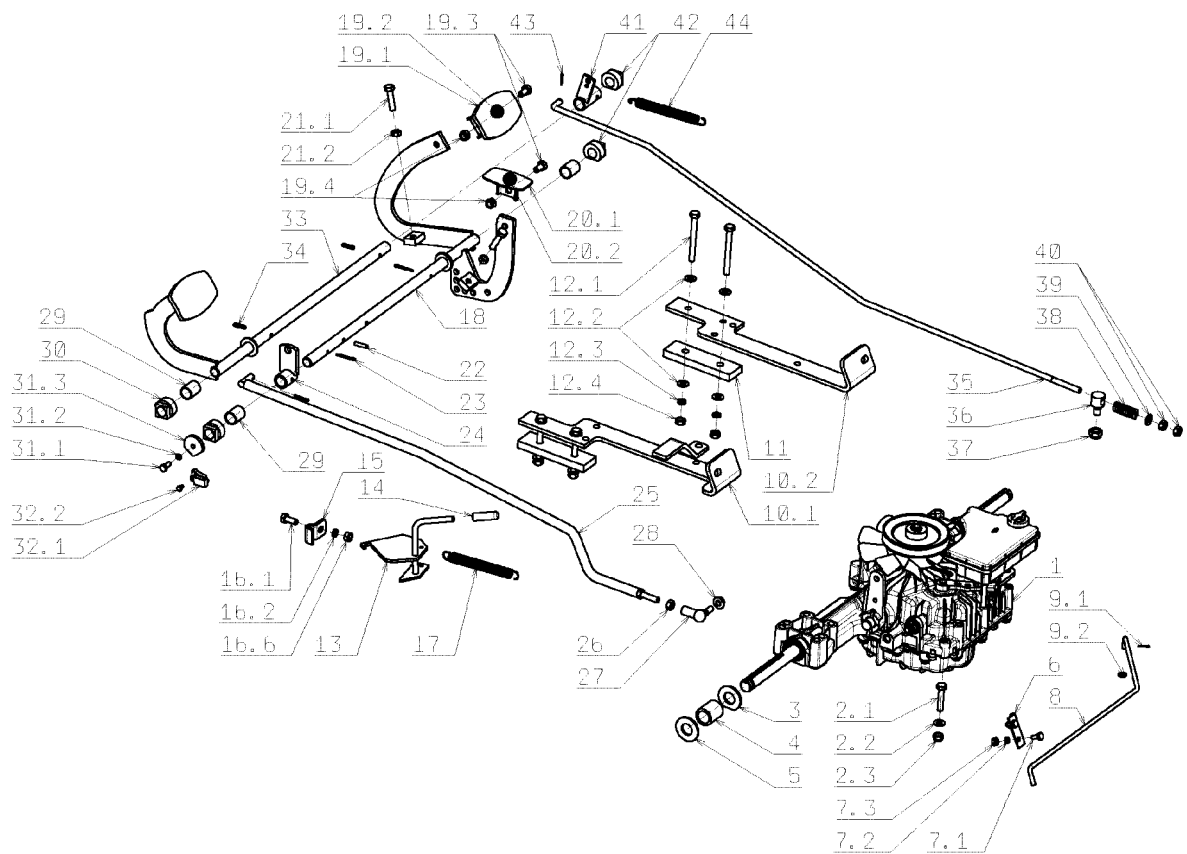

## Illustration    Getriebe

---

Bild Nr.	St.- Zahl	Teile Nr.	Beschreibung
1	1	SG947532991052	Getriebe
2.1	1	SGN309503559	Schraube
2.2	1	SGN311210503	Scheibe
2.3	1	SGN311129501	Mutter
3	4	SGS53209220836	Scheibe
4	2	SGN532150542	Distanzstück
5	6	SGS53209220815	Scheibe
6	1	SGS53211340391	Halter
7.1	2	SGN309203539	Schraube
7.2	2	SGN311214507	Scheibe
7.3	2	SGN311120506	Mutter
8	1	SGN532150724	Hebel
9.1	1	SGN311338513	Stift
9.2	1	SGN311210502	Scheibe
10.1	1	SGS53291336844	Halter
10.2	1	SGS53211340386	Halter
11	2	SGS53209230394	Scheibe
12.1	4	SGN309501571	Schraube
12.2	8	SGN311210503	Scheibe
12.3	4	SGN311214502	Scheibe
12.4	4	SGN311150503	Mutter
13	1	SGS53298071232	Hebel
14	1	SGN532150209	Deckel
15	1	SGS53208041236	Halter
16.1	1	SGN309503518	Schraube
16.2	1	SGN311214502	Scheibe
16.6	1	SGN311150503	Mutter
17	1	SGN315231160	Feder
18	1	SGS53298044221	Hebel
19.1	2	SGS53298051257	Fusshebel
19.2	2	SGN273151001	Deckung
19.3	3	SGN309503518	Schraube
19.4	3	SGN311129501	Mutter
20.1	1	SGS53298051258	Fusshebel
20.2	1	SGN273151011	Deckung

---

# Illustration    Getriebe

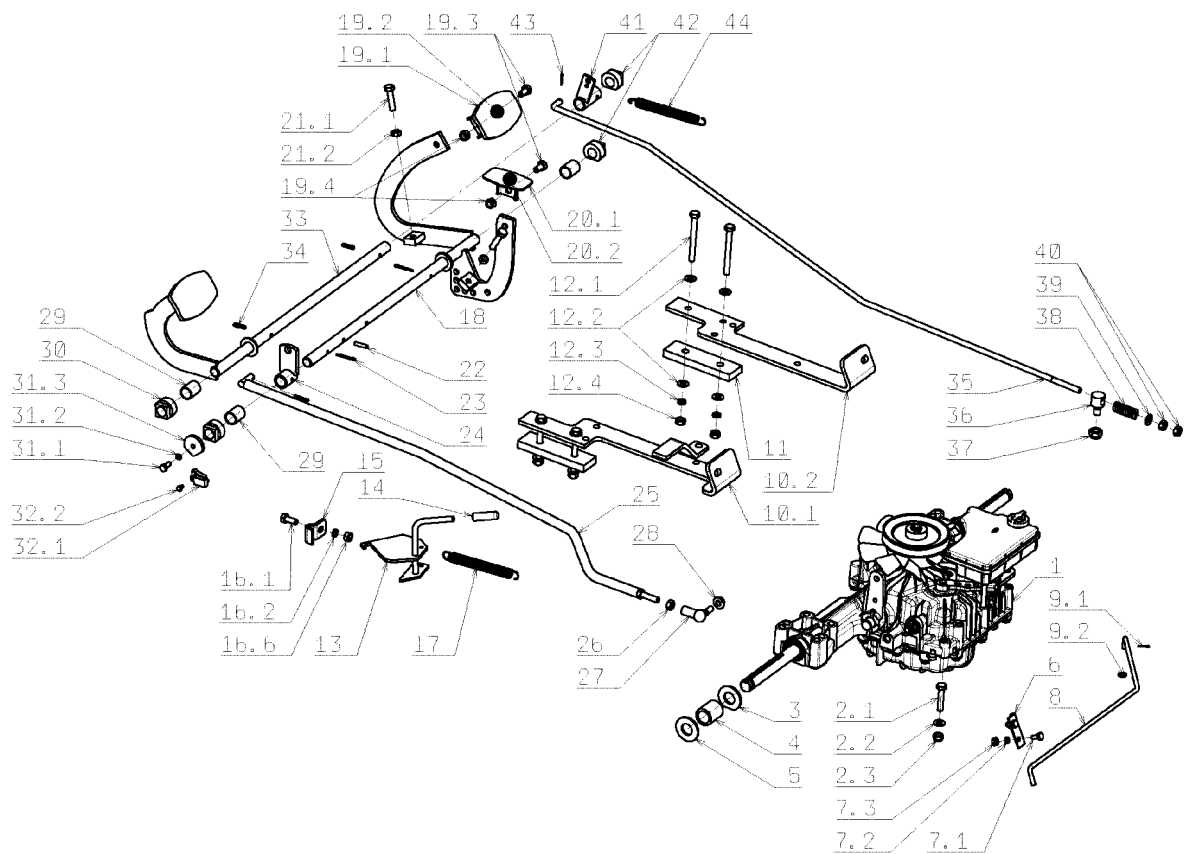

## Illustration    Getriebe

---

Bild Nr.	St.- Zahl	Teile Nr.	Beschreibung
21.1	2	SGN309503543	Schraube
21.2	2	SGN311150503	Mutter
22	1	SGN315238037	Stift
23	3	SGN311338517	Stift
24	1	SGS53298036482	Komplett arm
25	1	SGN532150725	Spannstange
26	1	SGN311150503	Mutter
27	1	SGN442073023	Winkelstahl
28	1	SGN311129520	Mutter
29	3	SGN532150541	Distanzstück
30	2	SGN722643023	Deckel
31.1	1	SGN309503508	Schraube
31.2	1	SGN311214501	Scheibe
31.3	1	SGS53209220835	Scheibe
32.1		-	Nicht verfügbar für diesen produkt
32.2	1	SGN309315011	Schraube
33	1	SG532980442263	Bremsepedal
34	2	SGN315238050	Stift
35	1	SGN532150721	Welle
36	1	SGN532150507	Schraube
37	1	SGN311129502	Mutter
38	1	SGN315231240	Feder
39	1	SGN311212517	Scheibe
40	2	SGN311120520	Mutter
41	1	SGS53298036518	Pedal komplett
42	2	SGN722643023	Deckel
43	1	SGN311338501	Stift
44		-	Nicht verfügbar für diesen produkt

Illustration    Grasfangkorb

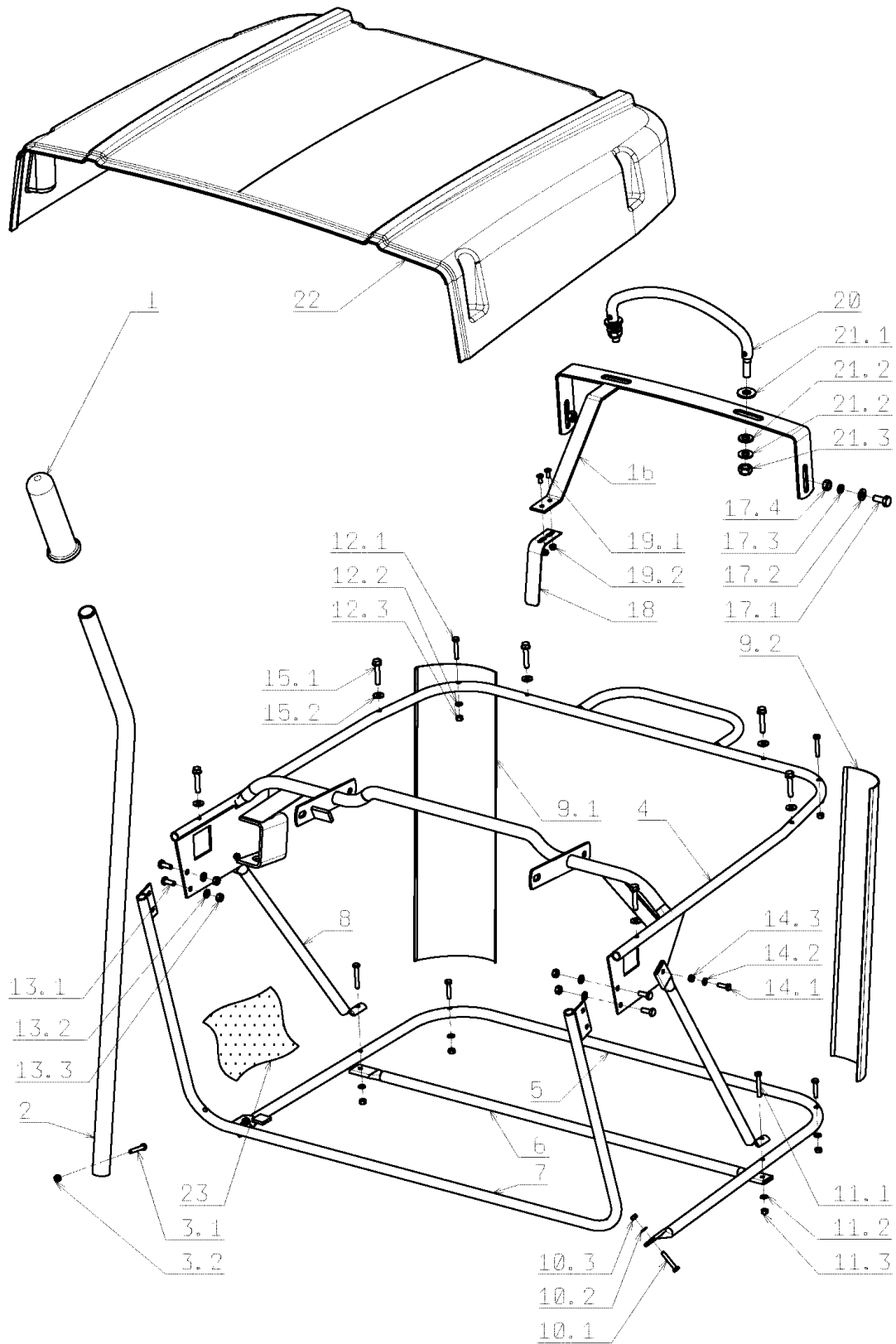

## Illustration    Grasfangkorb

---

Bild Nr.	St.- Zahl	Teile Nr.	Beschreibung
1	1	SGN532150007	Handgriff
2	1	SGN532150701	Hebel
3.1	1	SGN309203548	Schraube
3.2	1	SGN311129515	Mutter
4	1	SGN532150693	Oberer rahmen
5	1	SGN532150696	Rohr
6	1	SGN532150697	Rohr
7	1	SGN532150694	Rohr
8	2	SGN532150695	Verstaerkung
9.1	1	SGN532150699	Verstaerkung
9.2	1	SGN532150698	Verstaerkung
10.1	2	SGN309203555	Schraube
10.2	2	SGN311210501	Scheibe
10.3	2	SGN311129515	Mutter
11.1	2	SGN309203556	Schraube
11.2	2	SGN311210501	Scheibe
11.3	2	SGN311129515	Mutter
12.1	4	SGN309203557	Schraube
12.2	4	SGN311210501	Scheibe
12.3	4	SGN311129515	Mutter
13.1	4	SGN309019514	Schraube
13.2	4	SGN311212514	Scheibe
13.3	4	SGN311129515	Mutter
14.1	2	SGN309203539	Schraube
14.2	2	SGN311210501	Scheibe
14.3	2	SGN311129515	Mutter
15.1	6	SGN309315013	Schraube
15.2	-	-	Nicht verfügbar für diesen produkt
16	1	SGN532150901	Halter
17.1	2	SGN309503518	Schraube
17.2	2	SGN311210503	Scheibe
17.3	2	SGN311214502	Scheibe
17.4	2	SGN311120502	Mutter
18	1	SGN315231177	Feder
19.1	2	SGN309251513	Schraube
19.2	2	SGN311129515	Mutter
20	1	SG532150709	Handgriff
21.1	2	SG311212040	Scheibe
21.2	4	SGN311210504	Scheibe
21.3	2	SGN311129502	Mutter
22	1	SGN532150864	Deckel
23	1	SGN532150135	Ersatzsack

# Illustration Hinterachse

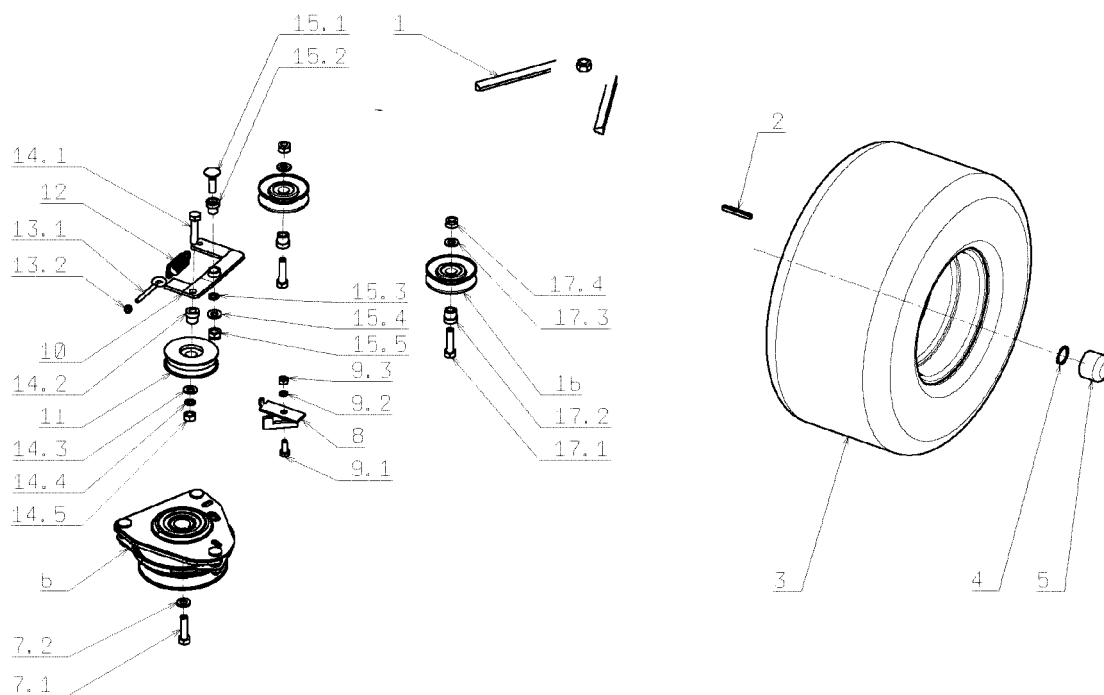

## Illustration    Hinterachse

---

Bild Nr.	St.- Zahl	Teile Nr.	Beschreibung
1	1	SGN272731202	Riemen 13x2600
2	2	SG532092312163	Feder
3	2	SG947000532094	Rad
4	2	SG311732008	Ring
5	2	SGN532150209	Deckel
6	1	SG947000532010	Kupplung
7.1	1	SG309579509	Schraube
7.2	1	SG311219516	Scheibe
8	1	SG532936362163	Führung
9.1	2	SGN309503518	Schraube
9.2	10	SGN311214502	Scheibe
9.3	7	SGN311150503	Mutter
10	1	SG532913322763	Halter
11	1	SGN532150733	Riemenscheibe
12	1	SG315231111	Feder
13.1	1	SG309578523	Schraube
13.2	1	SGN311129513	Mutter
14.1	1	SG309019529	Schraube
14.2	1	SG532150524	Lager
14.3	1	SGN311210504	Scheibe
14.4	1	SGN311214503	Scheibe
14.5	1	SGN311150506	Mutter
15.1	1	SG309203528	Schraube
15.2	1	SG532150545	Lager
15.3	1	SGN311210504	Scheibe
15.4	1	SGN311214503	Scheibe
15.5	1	SGN311150506	Mutter
16	2	SGN532150824	Riemenscheibe
17.1	2	SG309501518	Schraube
17.2	2	SG532150524	Lager
17.3	2	SGN311210504	Scheibe
17.4	2	SGN311129502	Mutter



Illustration Kapotte (1/3)

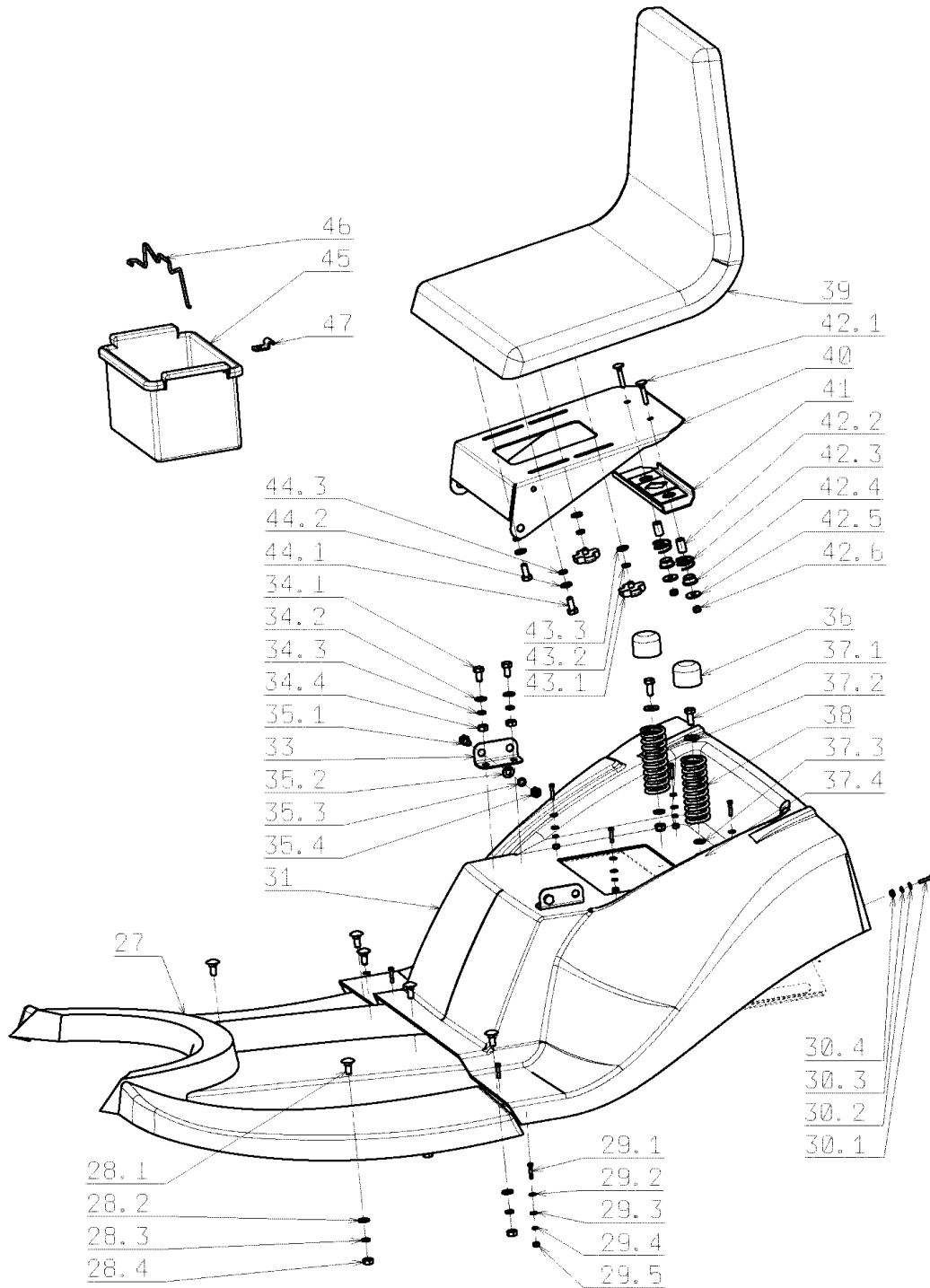

## Illustration Kapotte (1/3)

Bild Nr.	St.- Zahl	Teile Nr.	Beschreibung
27	1	SGN532150749	Boden
28.1	6	SGN309019508	Schraube
28.2	6	SGN311210503	Scheibe
28.3	6	SGN311214502	Scheibe
28.4	6	SGN311150503	Mutter
29.1	8	SGN309578502	Schraube
29.2	8	SGN311219501	Scheibe
29.3	8	SGN311212514	Scheibe
29.4	8	SGN311214507	Scheibe
29.5	8	SGN311120506	Mutter
30.1	6	SGN309203518	Schraube
30.2	6	SGN311212518	Scheibe
30.3	6	SGN311210506	Scheibe
30.4	6	SGN311129514	Mutter
31	1	SGN532150859	Rahmen
33	2	SGS53211340240:	Schraube
34.1	4	SGN309203503	Schraube
34.2	4	SGN311210503	Scheibe
34.3	4	SGN311214502	Scheibe
34.4	4	SGN311150503	Mutter
35.1	2	SGN309599012	Schraube
35.2	2	SGN311210503	Scheibe
35.3	2	SGN311214502	Scheibe
35.4	2	SGN311150503	Mutter
36	2	SGN532150208	Deckel
37.1	2	SGN309503512	Schraube
37.2	2	SGN311212517	Scheibe
37.3	2	SGN311210503	Scheibe
37.4	2	SGN311129501	Mutter
38	2	SGN315231124	Feder
39	1	SGN532150891	Sitz
40	1	SGS53201847243:	Halter
41	1	SGS53298336215:	Schalterträger komplett
42.1	2	SGN309019519	Schraube
42.2	2	SGN532150442	Distanzstück
42.3	2	SGN315231194	Feder
42.4	2	SGN722643019	Deckel
42.5	2	SGN311212520	Scheibe
42.6	2	SGN311129513	Mutter
43.1	2	SGN532150213	Mutter
43.2	2	SGN311213503	Scheibe
43.3	2	SGN311219002	Scheibe
44.1	2	SGN309503518	Schraube

Illustration Kapotte (1/3)

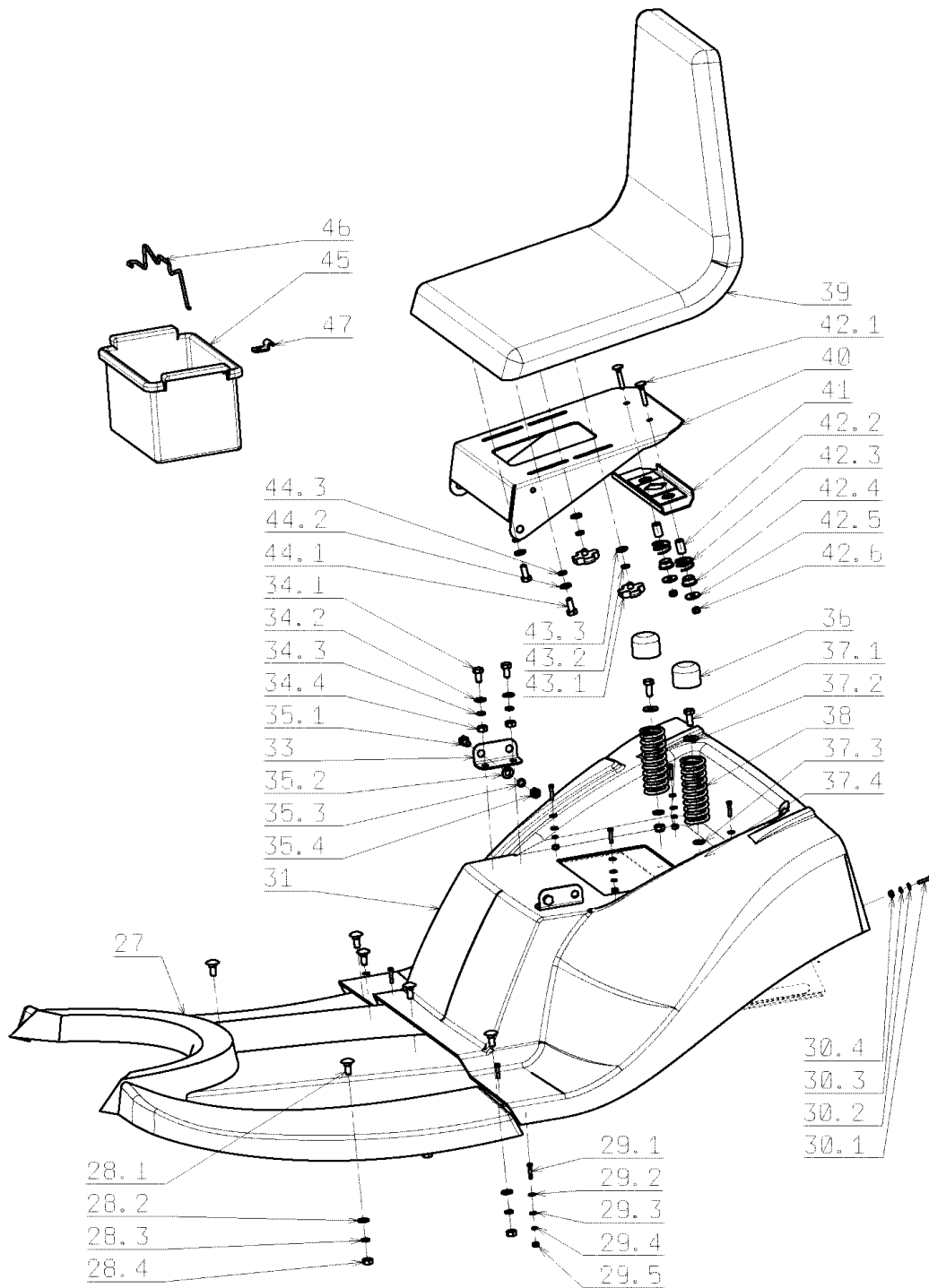

## Illustration Kapotte (1/3)

---

Bild Nr.	St.- Zahl	Teile Nr.	Beschreibung
44.2	2	SGN311210503	Scheibe
44.3	2	SGN311214502	Scheibe
45	1	SGN232130001	Batteriefach
46	1	SGN532880041	Halter
47	1	SGS53211341345	Schelle

Illustration Kapotte (2/3)

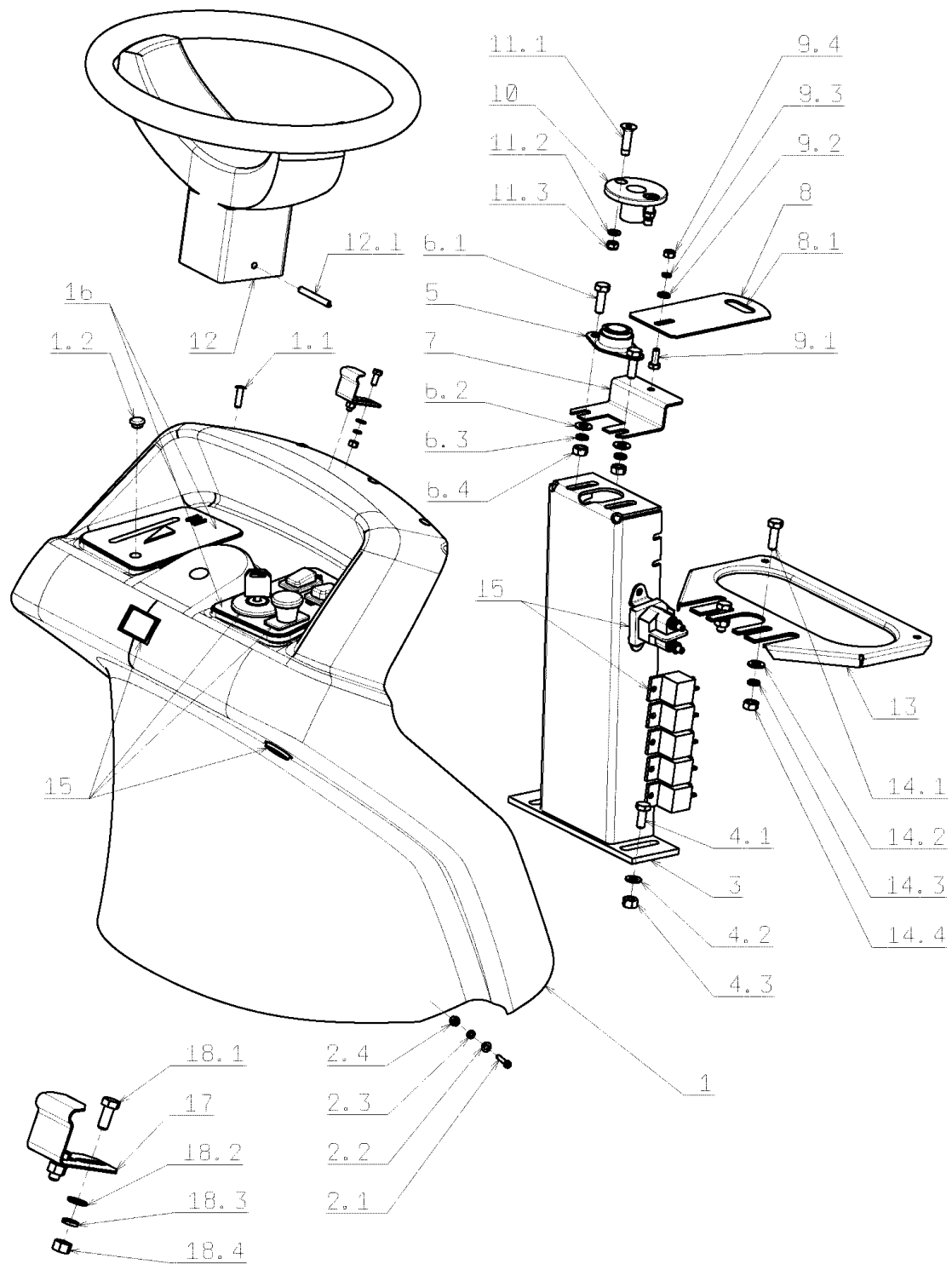

## Illustration Kapotte (2/3)

Bild Nr.	St.- Zahl	Teile Nr.	Beschreibung
1	1	SGN532150892	Blechtafel
1.1	4	SG532150238	Deckel
1.2		-	Nicht verfügbar für diesen produkt
2.1	4	SGN309019520	Schraube
2.2	4	SGN311212511	Scheibe
2.3	4	SGN311214507	Scheibe
2.4	4	SGN311120506	Mutter
3	1	SGS53291642204:	Lenkstock
4.1	4	SGN309503518	Schraube
4.2	4	SGN311214502	Scheibe
4.3	4	SGN311150503	Mutter
5	1	SG000324001	Lager
6.1	2	SGN309503512	Schraube
6.2	2	SGN311210503	Scheibe
6.3	2	SGN311214502	Scheibe
6.4	2	SGN311150503	Mutter
7	1	SGS53211341486:	Halter
8	1	SGS53211340469:	Halter
8.1	1	SGN273121027	Buchse
9.1	1	SGN309503508	Schraube
9.2	1	SGN311210502	Scheibe
9.3	1	SGN311214501	Scheibe
9.4	1	SGN311150504	Mutter
10	1	SGS53201652225:	Lenkradhülle
11.1	2	SGN309578503	Schraube
11.2	2	SGN311210502	Scheibe
11.3	2	SGN311129513	Mutter
12	1	SGN443821004	Lenkrad
12.1	1	SGN315238031	Stift
13	1	SGS53298342202:	Halter
14.1	2	SGN309503512	Schraube
14.2	2	SGN311210503	Scheibe
14.3	2	SGN311214502	Scheibe
14.4	2	SGN311150503	Mutter
15		-	Nicht verfügbar für diesen produkt
16		-	Nicht verfügbar für diesen produkt
17	1	SGS53209742230:	Feder
18.1	2	SGN309203548	Schraube
18.2	2	SGN311210501	Scheibe
18.3	2	SGN311214507	Scheibe

Illustration Kapotte (2/3)

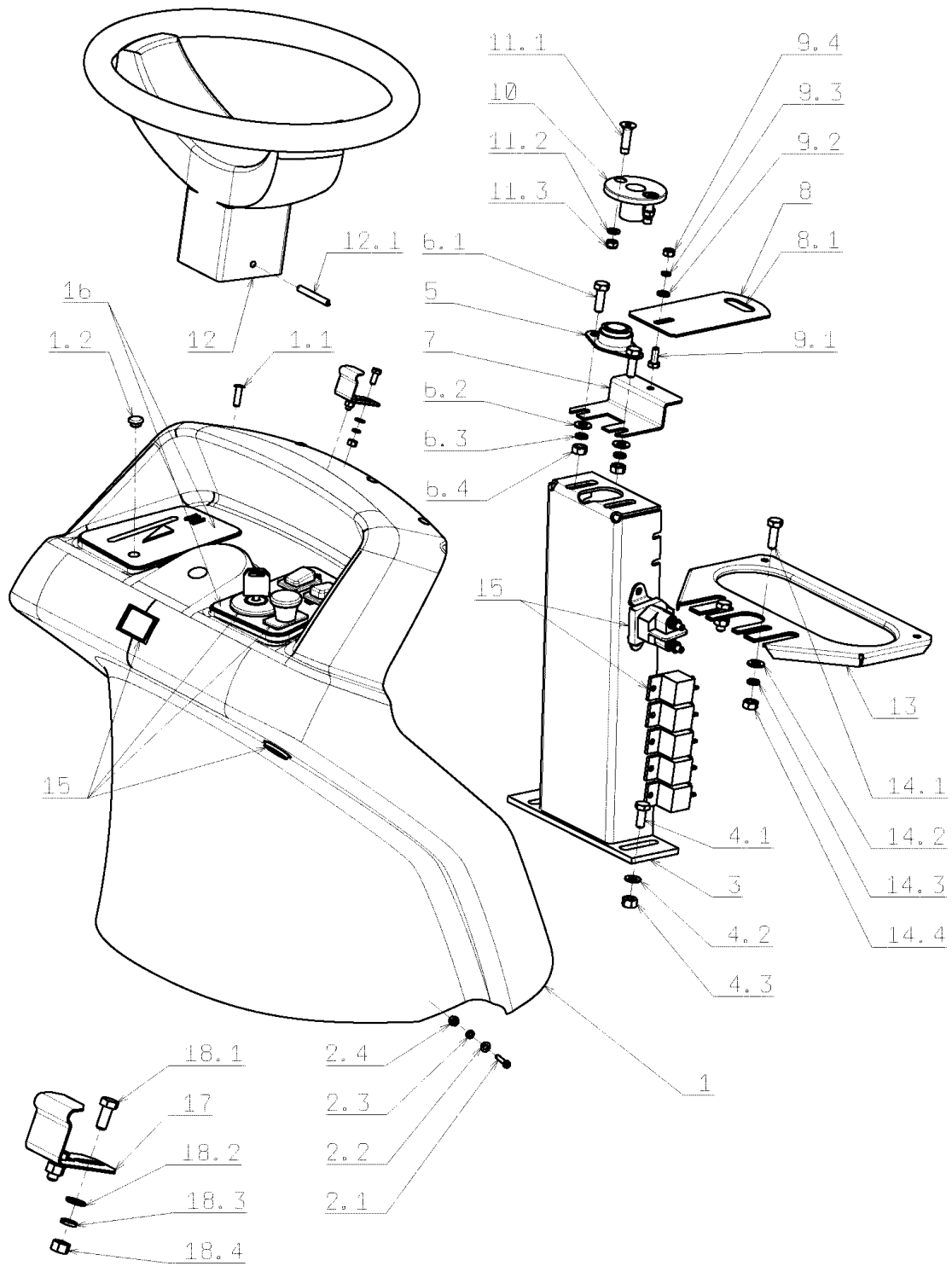

## Illustration Kapotte (2/3)

---

Bild Nr.	St.- Zahl	Teile Nr.	Beschreibung
18.4	2	SGN311120506	Mutter



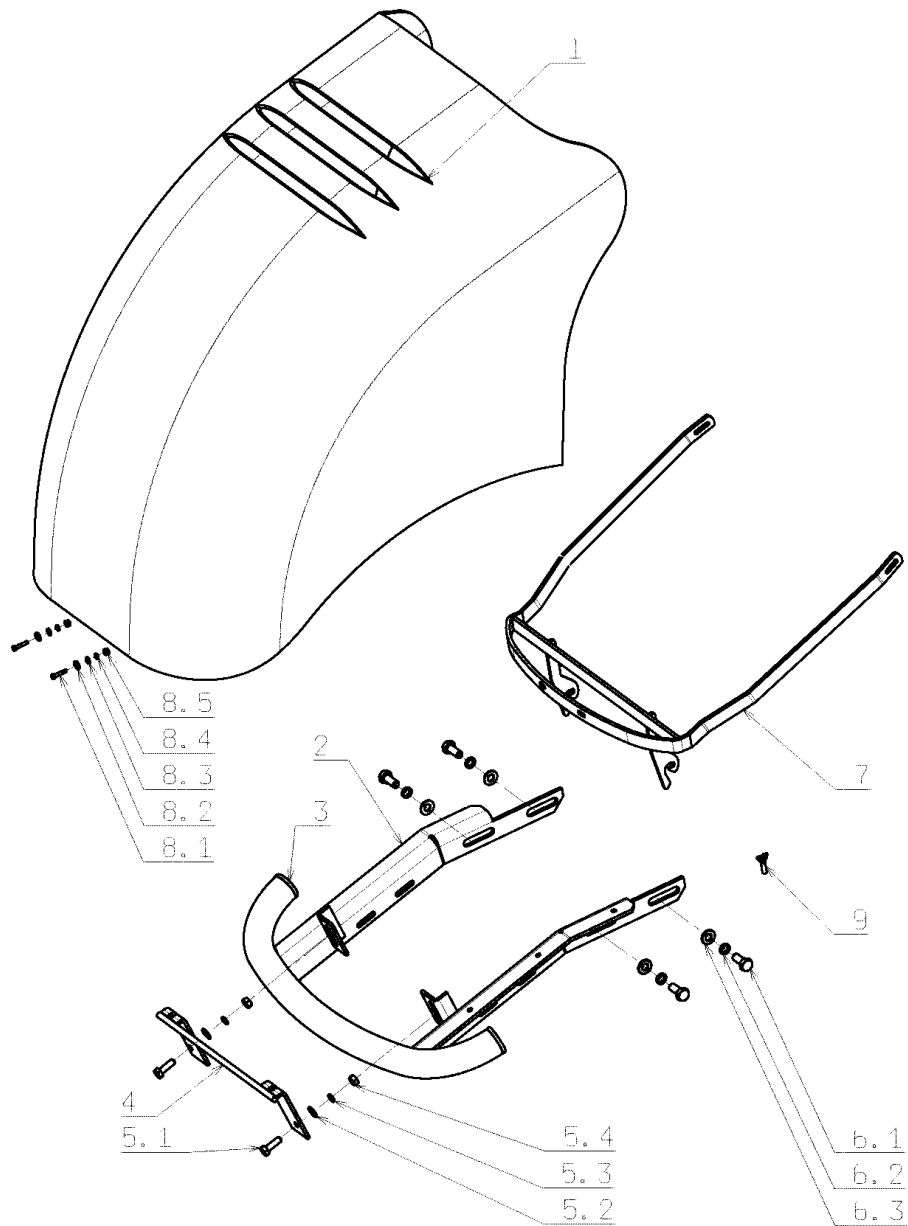

## Illustration Kapotte (3/3)

---

Bild Nr.	St.- Zahl	Teile Nr.	Beschreibung
1	1	SGS53291849305	Haube
2	1	SGS53291845207	Stossstangen
3	2	SGN321841068	Blechtafel
4	1	SGS53291340295	Halter
5.1	2	SGN309503518	Schraube
5.2	2	SGN311210503	Scheibe
5.3	2	SGN311214502	Scheibe
5.4	2	SGN311150503	Mutter
6.1	4	SGN309503502	Schraube
6.2	4	SGN311214503	Scheibe
6.3	4	SGN311210504	Scheibe
7	1	SGS53291846225	Halter
8.1	4	SGN309019521	Schraube
8.2	4	SGN273192027	Scheibe
8.3	4	SGN311212511	Scheibe
8.4	4	SGN311214507	Scheibe
8.5	4	SGN311120506	Mutter
9	-	-	Nicht verfügbar für diesen produkt

# Illustration Lenkgetriebe

---

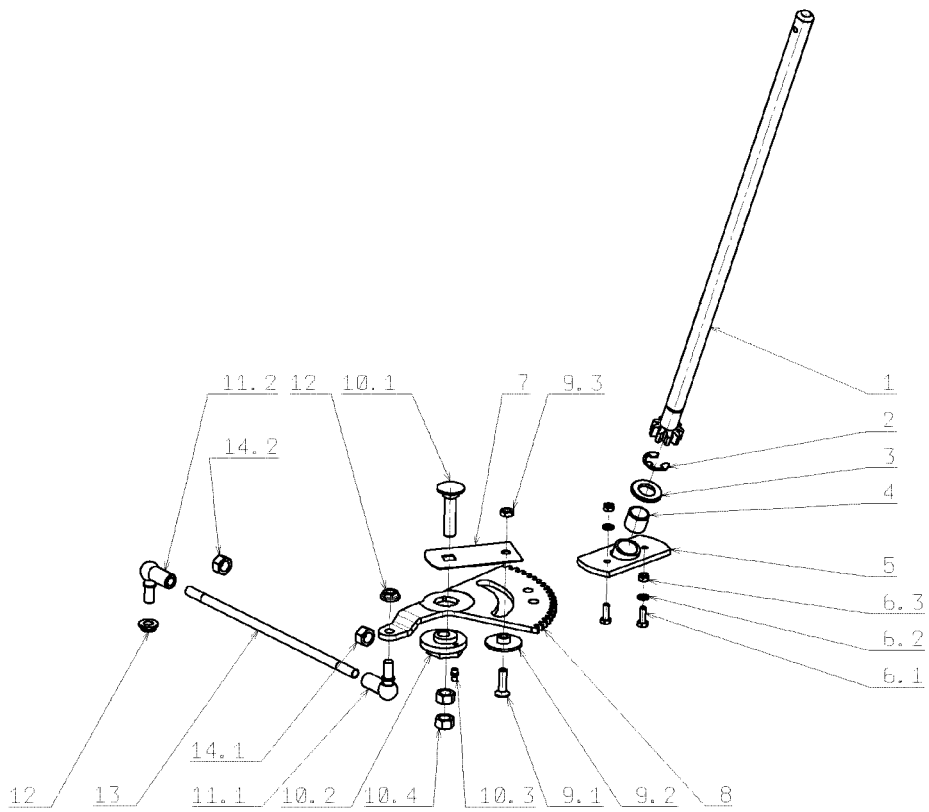

## Illustration Lenkgetriebe

---

Bild Nr.	St.- Zahl	Teile Nr.	Beschreibung
1	1	SGS53293025216	Ritzel
2	1	SG311732008	Ring
3	1	SG311210514	Scheibe
4	1	SG323721002	Lager
5	1	SG532938703433	Halter
6.1	2	SGN309503548	Schraube
6.2	2	SGN311212516	Scheibe
6.3	2	SGN311129513	Mutter
7	1	SG532113322803	Platte
8	1	SGS53203332214	Zahnrad
9.1	1	SG309578506	Schraube
9.2	1	SG532150538	Distanzstuck
9.3	1	SGN311120520	Mutter
10.1	1	SG309019522	Schraube
10.2	1	SG532080272033	Exzenter
10.3	1	SGN425111004	Fettnippel
10.4	2	SG311150505	Mutter
11.1	1	SG442073019	Dichtung
11.2	1	SG442073020	Dichtung
12	2	SG311129521	Mutter
13	1	SG532980125	Distanzstuck
14.1	1	SG311120539	Mutter
14.2	1	SG311150505	Mutter

# Illustration Mäheraushebung-schaltung

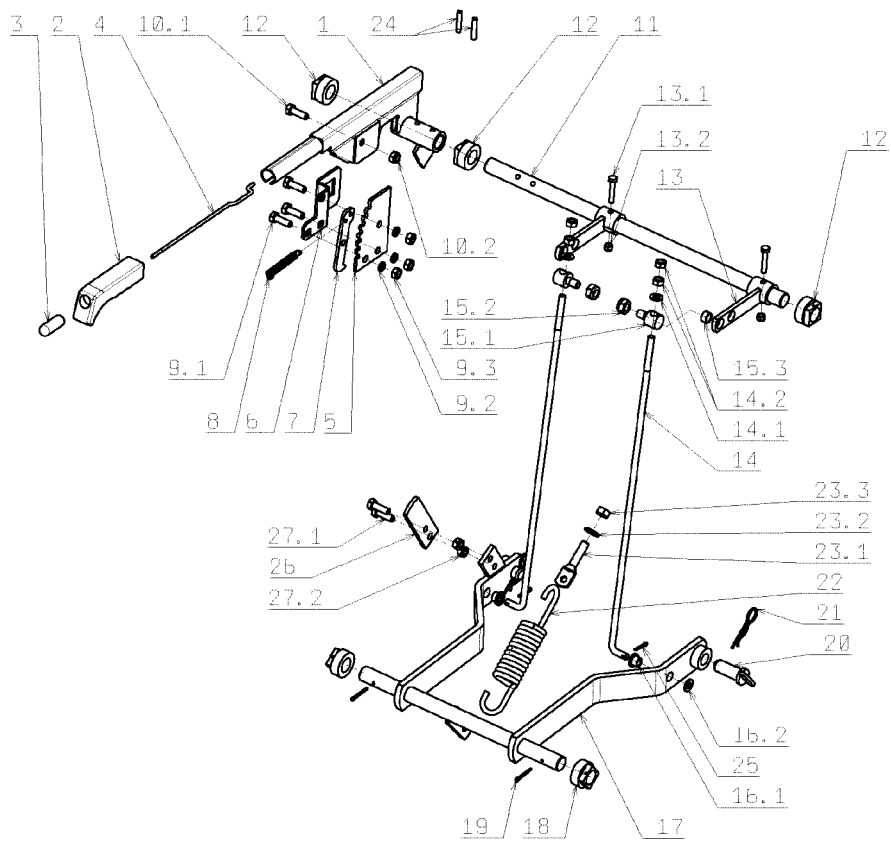

## Illustration Mäheraushebung-schaltung

Bild Nr.	St.-Zahl	Teile Nr.	Beschreibung
1	1	SGS53298052216:	Hebel
2	1	SGN532150049	Handgriff
3	1	SGN722643016	Toranschluss
4	1	SGN315238034	Pleuel
5	1	SGS53203732218:	Kolbenring
6	1	SGS53211341418:	Halter
7	1	SGS53203732211:	Platte
8	1	SGN315231158	Feder
9.1	3	SGN309503512	Schraube
9.2	3	SGN311214502	Scheibe
9.3	3	SGN311150503	Mutter
10.1	1	SGN309503512	Schraube
10.2	1	SGN311129501	Mutter
11	1	SGS53203810285:	Welle
12	3	SGN722643022	Deckel
13	2	SGS53298046285:	Komplett arm
13.1	2	SGN309501568	Schraube
13.2	2	SGN311129513	Mutter
14	2	SGN532150719	Spannstange
14.1	2	SGN311210503	Scheibe
14.2	4	SGN311150503	Mutter
15.1	2	SGN532150507	Schraube
15.2	2	SGN311129502	Mutter
15.3	2	SGN532150729	Mutter
16.1	2	SGN532150537	Ring
16.2	2	SGN311210503	Scheibe
17	1	SGS53298050810:	Hebel
18	2	SGN722643022	Deckel
19	2	SGN311338517	Stift
20	2	SGS53299346215:	Stift
21	2	SGN315238035	Stift
22	1	SGN315231165	Feder
23.1	1	SGN309599018	Schraube
23.2	1	SGN311214503	Scheibe
23.3	1	SGN311150506	Mutter
24	2	SGN315238041	Stift
25	2	SGN311338516	Stift

# Illustration Mäheraushebung-schaltung

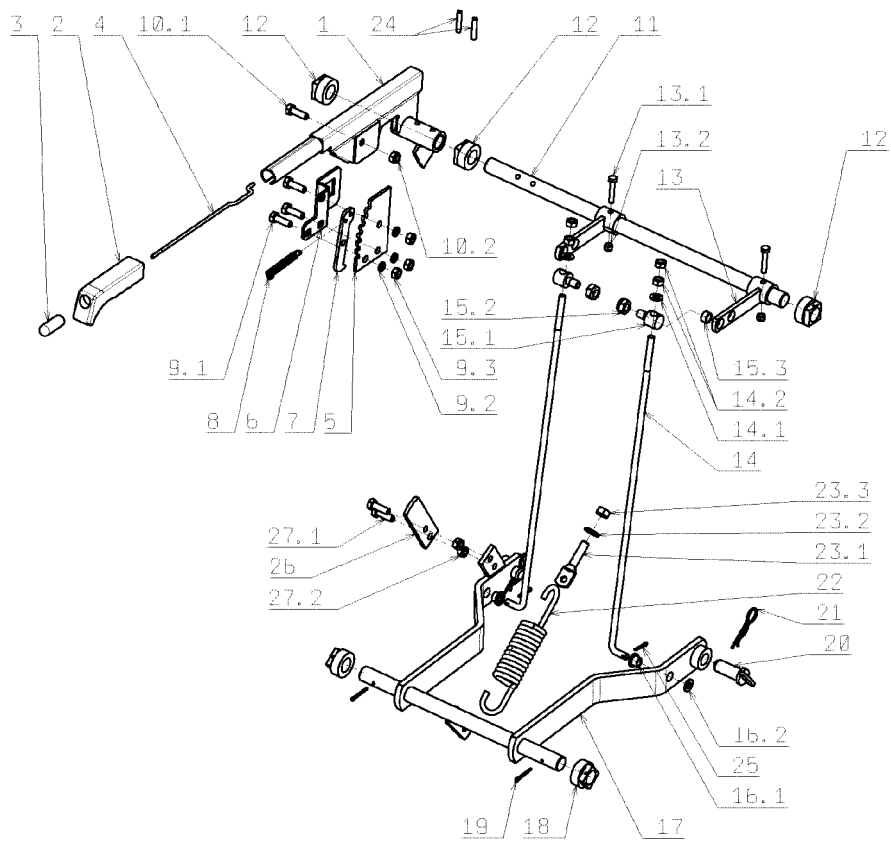

## Illustration Mäheraushebung-schaltung

---

Bild Nr.	St.- Zahl	Teile Nr.	Beschreibung
26	1	SGS53211432722	Platte
27.1	2	SGN309578522	Schraube
27.2	2	SGN311129501	Mutter



# Illustration Motor

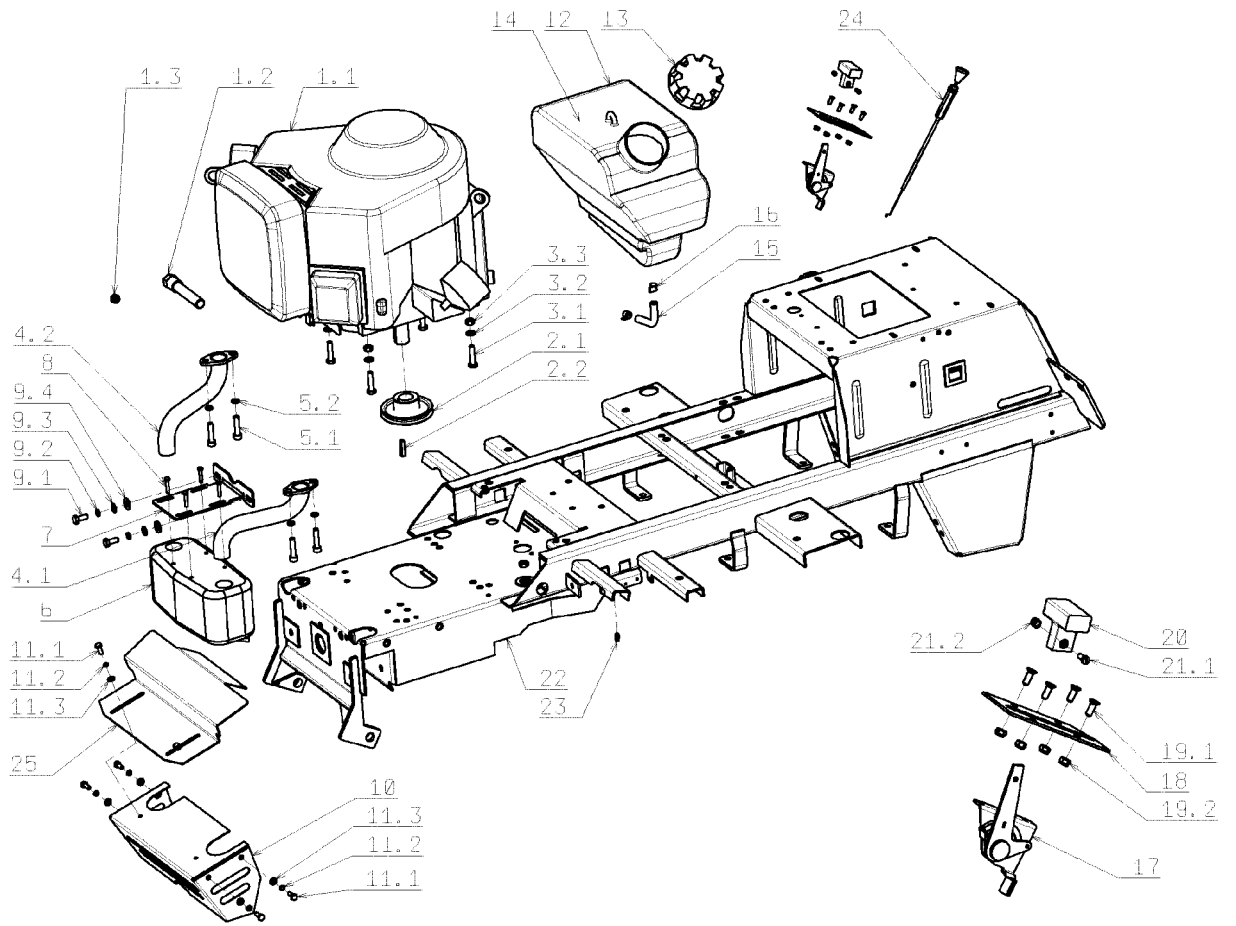

## Illustration Motor

Bild Nr.	St.-Zahl	Teile Nr.	Beschreibung
1.1		-	Nicht verfügbar für diesen produkt
1.2	1	SGS53292726204:	Aufsatz
1.3	1	SGN311122501	Mutter
2.1	1	SGN532150439	Scheibe
2.2	1	SGS53209231213:	Keil
3.1	4	SGN309503543	Schraube
3.2	4	SGN311214502	Scheibe
3.3	4	SGN311150503	Mutter
4.1	1	SGN532150791	Rohr
4.2	1	SGN532150790	Rohr
5.1	4	SGN309503518	Schraube
5.2	4	SGN311214502	Scheibe
6	1	SGN443900129	Auspuff
7	1	SGS53211340448:	Halter
8	4	SGN309315010	Schraube
9.1	2	SGN309503518	Schraube
9.2	2	SGN311214502	Scheibe
9.3	2	SGN311210503	Scheibe
9.4	2	SGN311212517	Scheibe
10	1	SGS53298542333:	Deckel
11.1	6	SGN309503508	Schraube
11.2	6	SGN311214501	Scheibe
11.3	6	SGN311210502	Scheibe
12	1	SGS53202766204:	Tank
13	1	SGN321841017	Stopfen
14	1	SGN315238005	Stift
15	1	SGS53219920226:	Kraftstoffleitung
16	2	SGN000532058	Schelle
17	1	SGN000443006	Hebel
19.1	4	SGN309251514	Schraube
19.2	4	SGN311129515	Mutter
20	1	SGN443900093	Hebel
21.1	1	SGN309231505	Schraube
21.2	1	SGN311129514	Mutter
22	1	SGS53291296263:	Rahmen
23	2	SGN425111004	Fettnippel
24	1	SGN443612011	Starterhebel
25	1	SGS53208541574:	Deckel

# Illustration Schneidwerkzeug (1/2)

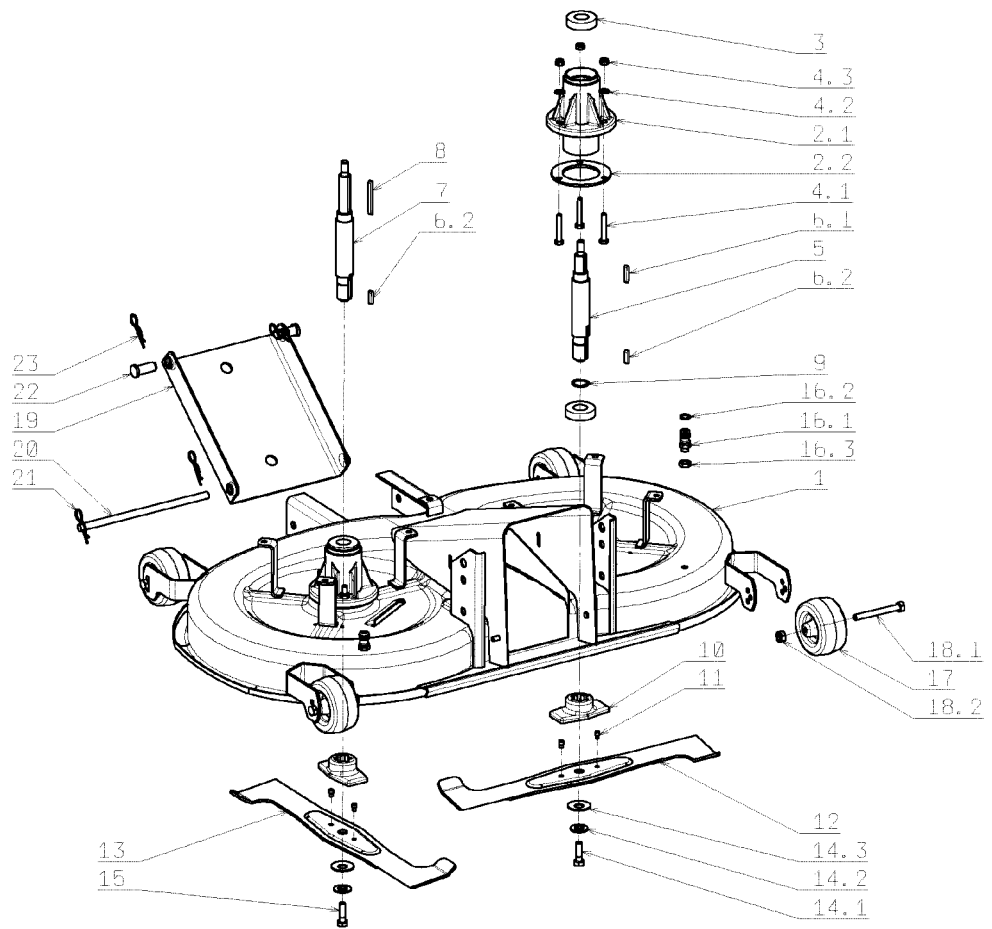

## Illustration    Schneidwerkzeug (1/2)

---

Bild Nr.	St.- Zahl	Teile Nr.	Beschreibung
1	1	SG532950472083	Deck
2.1	2	SG532038523833	Deckel
2.2	2	SG532098203373	Dichtung
3	4	SG324162099	Lager
4.1	6	SGN309503543	Schraube
4.2	6	SGN311210503	Scheibe
4.3	6	SGN311129501	Mutter
5	1	SG532038128023	Welle
6.1	1	SG311726009	Feder
6.2	2	SG311726014	Feder
7	1	SG532038128033	Welle
8	1	SG311726019	Feder
9	2	SG311733014	Ring
10	2	SG532098212403	Anpassungsglied
11	4	SG532980077	Buchse
12	1	SG532050422543	Blatt
13	1	SG532050422533	Blatt
14.1	1	SG309599017	Schraube
14.2	2	SG532150519	Scheibe
14.3	2	SG311219503	Scheibe
15	1	SG309599008	Schraube
16.1	2	SG532150533	Scheibe
16.2	2	SGN273111057	Ring
16.3	2	SG311120511	Mutter
17	4	SG532940117	Rad
18.1	4	SG309501567	Schraube
18.2	4	SGN311129501	Mutter
19	1	SG532080503503	Einstellen
20	1	SG532193102893	Stift
21	2	SGN315238035	Stift
22	2	SG311613002	Buchse
23	4	SG315238003	Stift

# Illustration Schneidwerkzeug (2/2)

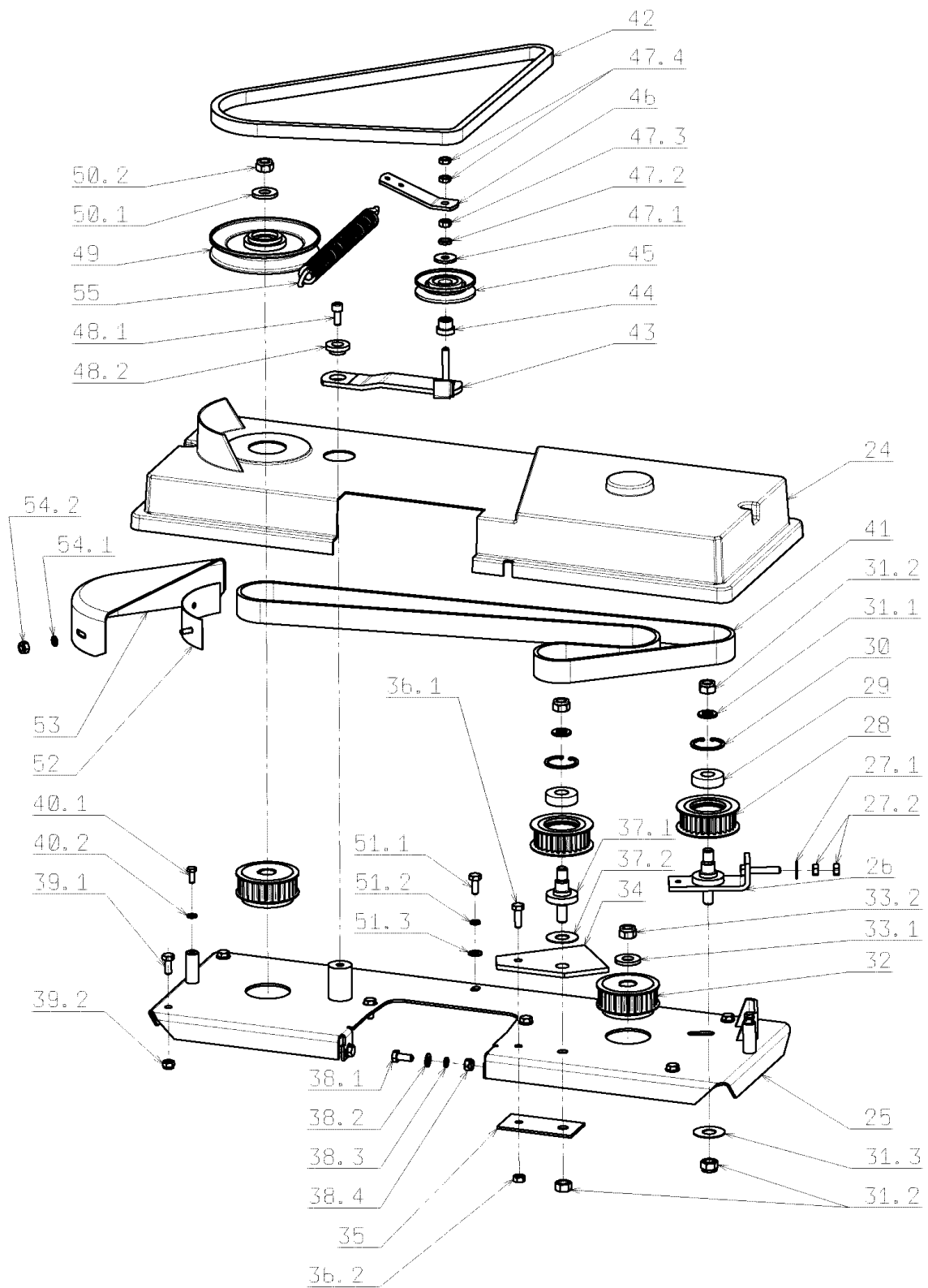

## Illustration    Schneidwerkzeug (2/2)

Bild Nr.	St.- Zahl	Teile Nr.	Beschreibung
24	1	SGN532150865	Deckel
25	1	SGS53298542344	Platte
26	1	SG532914412313	Mutter
27.1	1	SGN311212517	Scheibe
27.2	2	SGN311150503	Mutter
28	1	SGN532150836	Riemenscheibe
29		-	Nicht verfügbar für diesen produkt
30		-	Nicht verfügbar für diesen produkt
31.1	2	SGN311210505	Scheibe
31.2	4	SGN311129505	Mutter
31.3	1	SG532092207533	Scheibe
32	2	SGN532150860	Riemenscheibe
33.1	1	SG532092207273	Scheibe
33.2	1	SGN311129505	Mutter
34	1	SG532096303973	Halter
36.1	1	SGN309503512	Schraube
36.2	1	SGN311129501	Mutter
37.1	1	SGN532150807	Stiftschraube
37.2	1	SG532092207703	Scheibe
38.1	2	SG309019501	Schraube
38.2	2	SGN311210505	Scheibe
38.3	2	SGN311210503	Scheibe
38.4	2	SGN311129501	Mutter
39.1	6	SGN309503518	Schraube
39.2	6	SGN311129501	Mutter
40.1	2	SGN309503548	Schraube
40.2	6	SGN311212516	Scheibe
41	1	SG272211006	Riemen
42	1	SG947272731192	Riemen 17x1400
43	1	SG532913422403	Hebel
44	1	SG532150517	Buchse
45	1	SGN532150784	Kompensator
46	1	SG532113402353	Hebel
47.1	1	SGN311212508	Scheibe
47.2	1	SGN311214502	Scheibe
47.3	1	SGN311150503	Mutter
47.4	2	SGN311120520	Mutter
48.1	1	SGN309578529	Schraube
48.2	1	SGN532150736	Scheibe
49	1	SG532150165	Riemenscheibe
50.1	1	SG532092207273	Scheibe
50.2	1	SGN311129505	Mutter
51.1	1	SGN309503518	Schraube
51.2	1	SGN311214502	Scheibe
51.3	1	SGN311210503	Scheibe

Illustration Schneidwerkzeug (2/2)

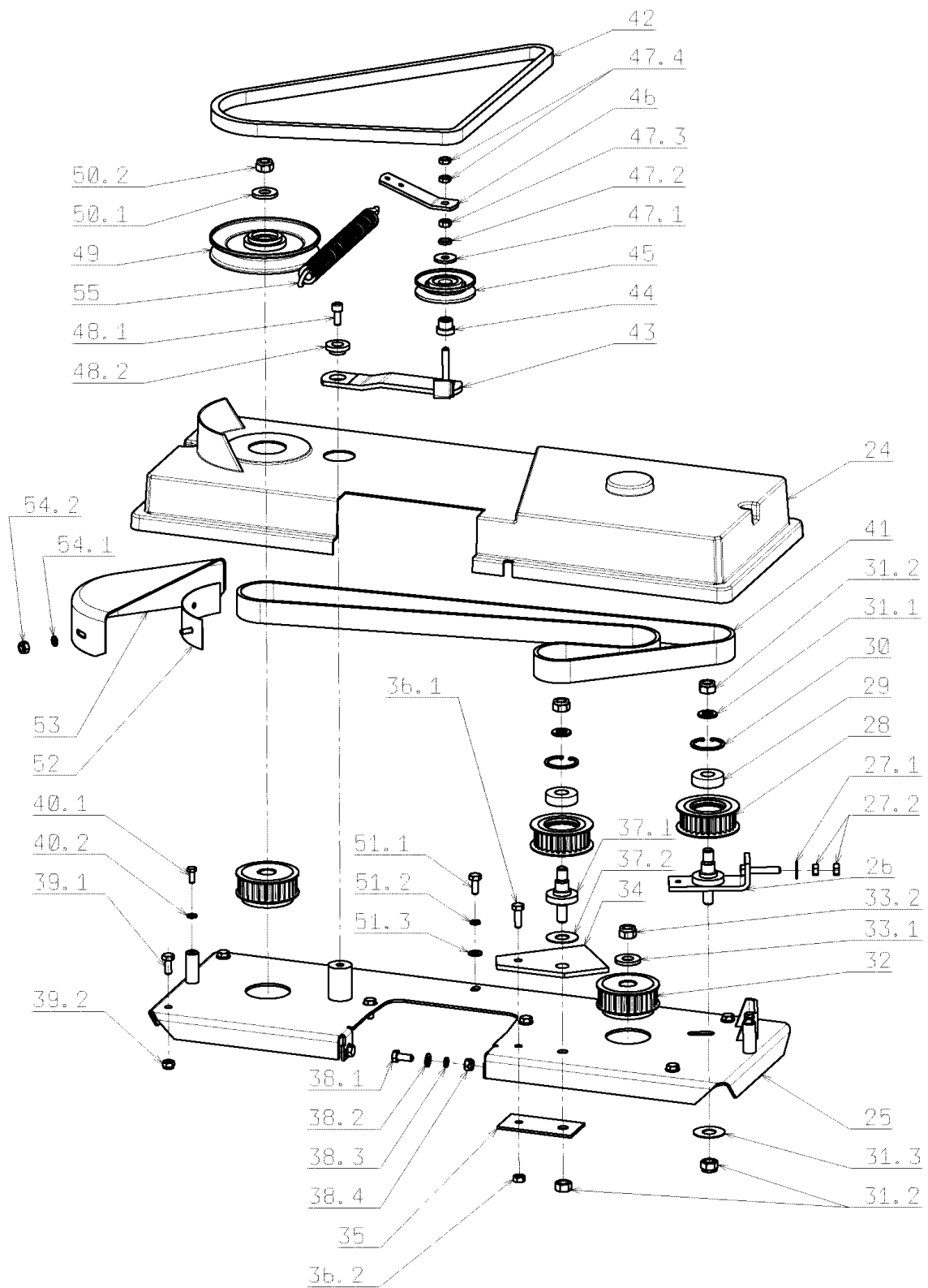

## Illustration    Schneidwerkzeug (2/2)

---

Bild Nr.	St.- Zahl	Teile Nr.	Beschreibung
52	1	SG532985402733	Dichtung
53	1	SG532150559	Riemen
54.1	2	SGN311212516	Scheibe
54.2	2	SGN311129513	Mutter
55	1	SG315231193	Feder



# Illustration Vorderachse

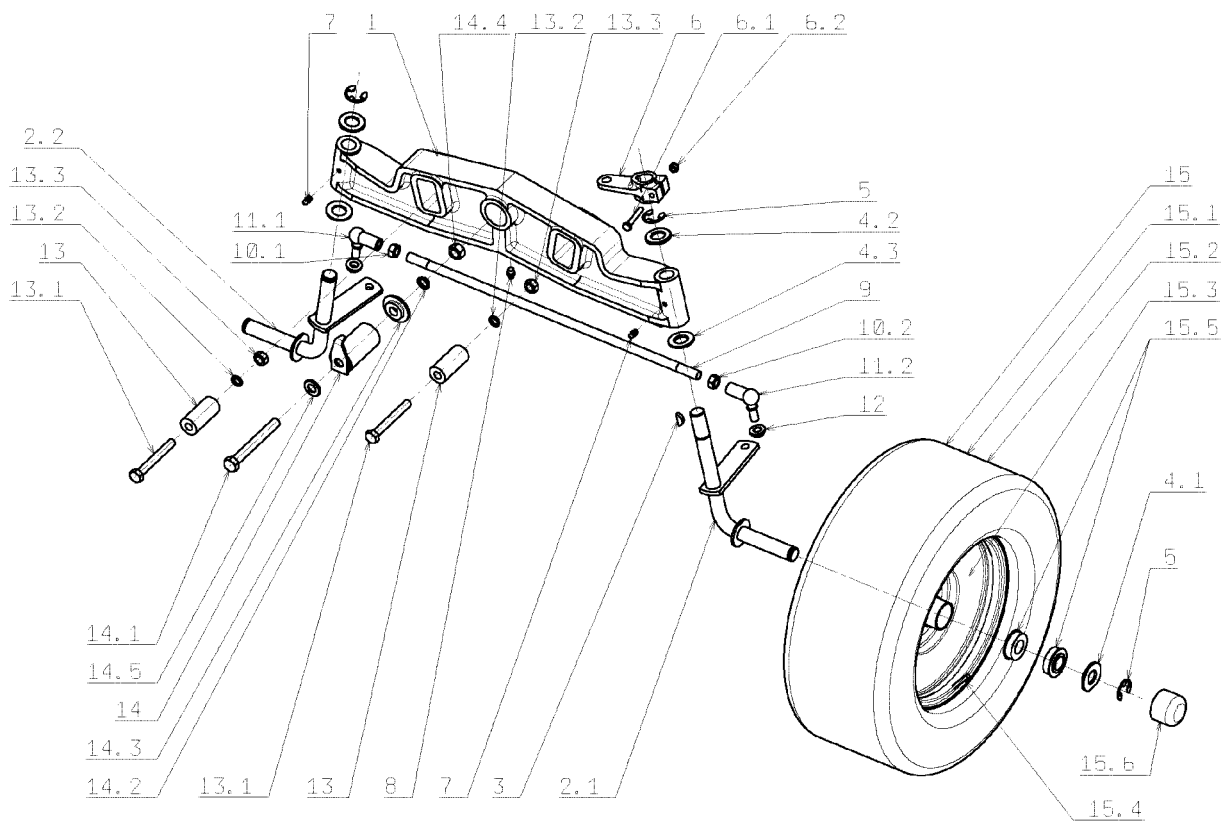

## Illustration Vorderachse

---

Bild Nr.	St.- Zahl	Teile Nr.	Beschreibung
1	1	SG532016542063	Vorn achse
2.1	1	SG532916432143	Stift
2.2	1	SG532916432153	Stift
3	1	SG311728003	Feder
4.1	2	SGS53209220815	Scheibe
4.2	4	SGS53209220815	Scheibe
4.3	4	SG311210514	Scheibe
5	2	SG311732008	Ring
6	1	SG532080503603	Hebel
6.1	1	SG309203524	Schraube
6.2	1	SGN311129513	Mutter
7	2	SGN425111004	Fettnippel
8	1	SG425111016	Fettnippel
9	1	SG532980126	Stange
10.1	1	SG311150505	Mutter
10.2	1	SG311120539	Mutter
11.1	1	SG442073020	Dichtung
11.2	1	SG442073019	Dichtung
12	2	SG311129521	Mutter
13	2	SG532150543	Distanzstuck
13.1	2	SG309501527	Schraube
13.2	2	SGN311214503	Scheibe
13.3	2	SGN311150506	Mutter
14	1	SG532993164373	Stift
14.1	1	SG309501534	Schraube
14.2	1	SG311214504	Scheibe
14.3	1	SG532150518	Scheibe
14.4	1	SG311150505	Mutter
14.5	1	SGN311210505	Scheibe
15	2	SG532940111	Rad
15.1	2	SG000532123	Reifen
15.2	2	SG000532125	Reifenschlauch
15.3	2	SG000532124	Schneidblatt
15.4	2	SG000532135	Ventil
15.5	4	SGN324196019	Lager
15.6	2	SGN532150711	Kopf